

# DOSSIER DE TRAVAIL D'ÉTÉ

## MOYENNE SECTION



## ANNÉE SCOLAIRE 2019-2020

**NOM DE L'ÉLÈVE :** .....

# SEMAINE 1

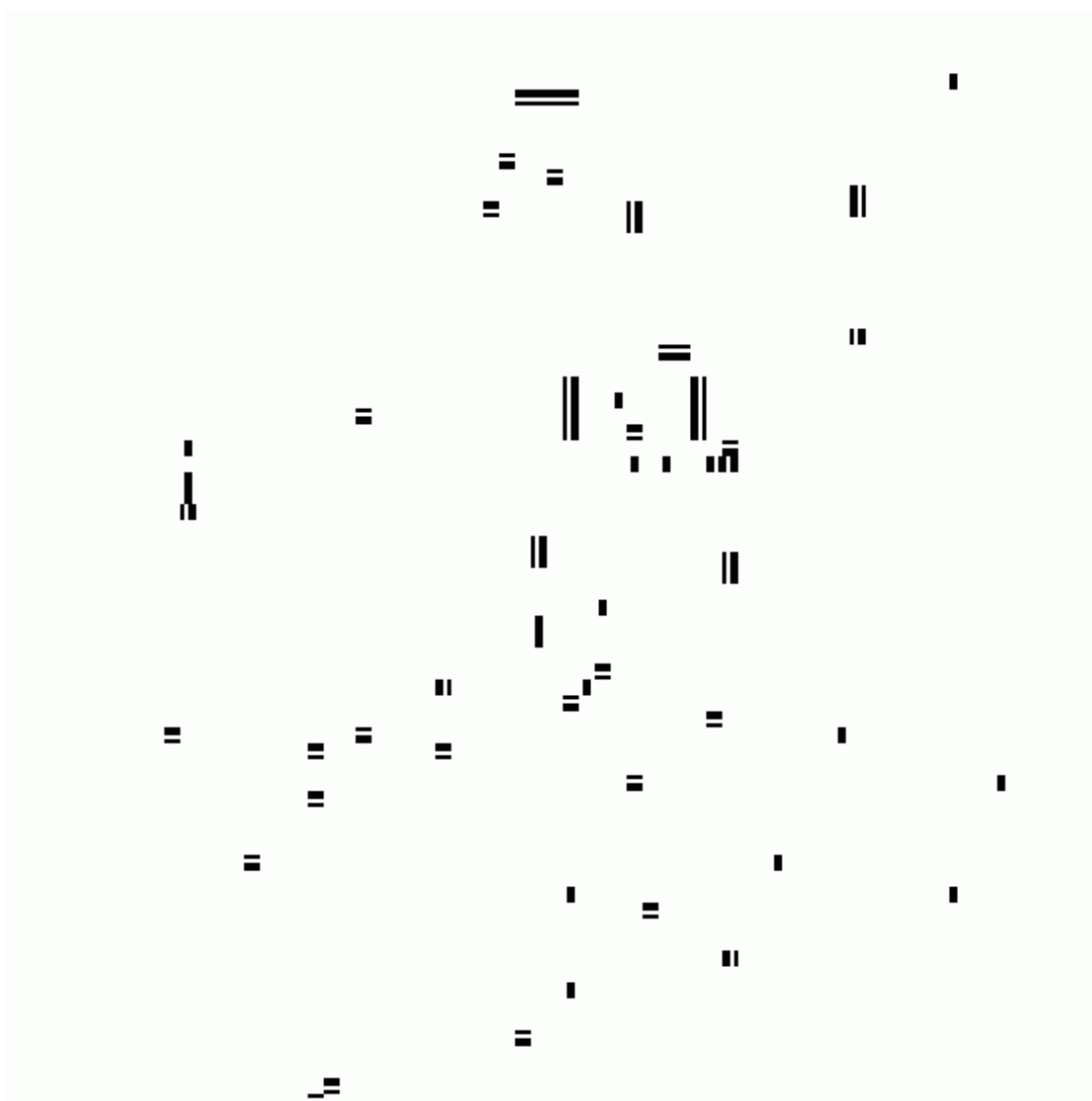

# Les vagues

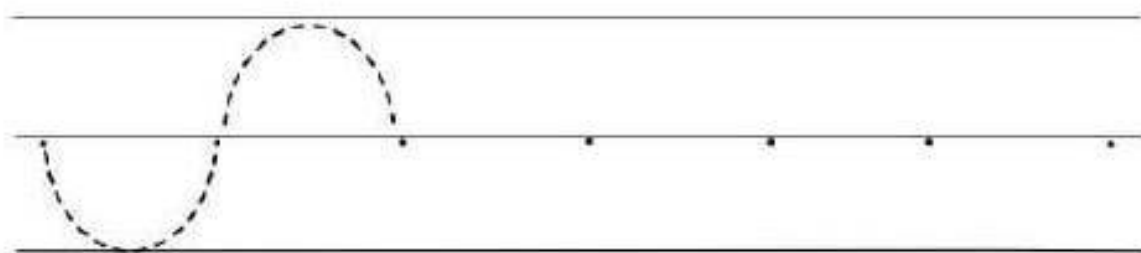

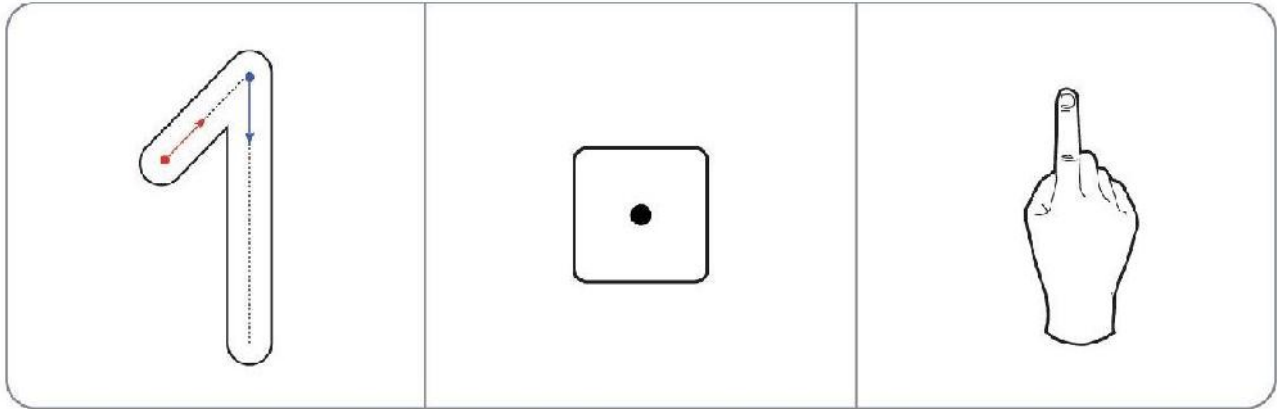

1. Continue les lignes.

Handwriting practice lines for the number 1. The first row shows a sequence of six starting points: a pencil icon, a diagonal line with a yellow dot at the top, a vertical line with a yellow dot at the top, and three purple dots. The second row shows a sequence of six starting points: a solid number 1, a dashed number 1, a dotted number 1, and three purple dots. The remaining three rows are empty lines for independent practice.

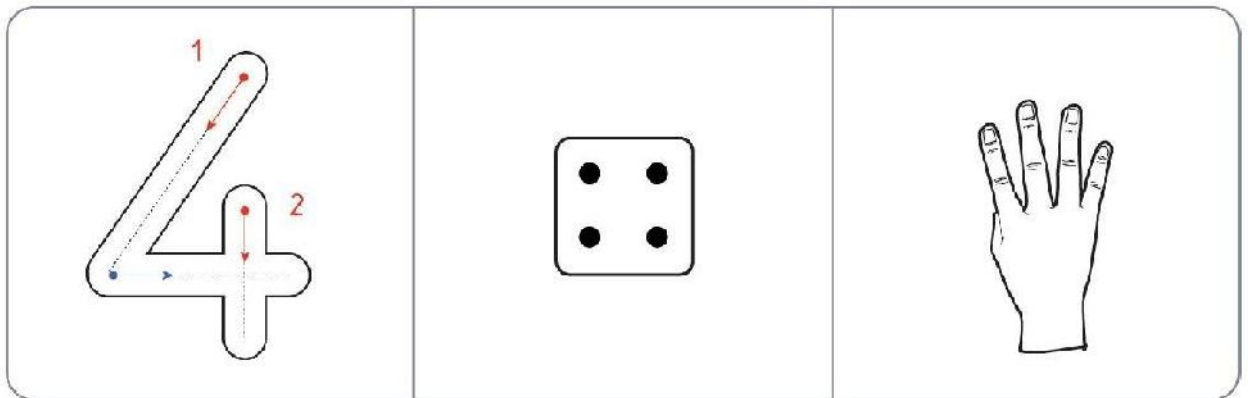

1. Continue les lignes.

Handwriting practice lines for the number 4. Each row contains a sequence of lines to be completed:

- Row 1: A solid diagonal line from bottom-left to top-right, followed by two dashed diagonal lines, and then three single purple dots on the top line.
- Row 2: A solid L-shaped line (diagonal then horizontal), followed by two dashed L-shaped lines, and then three pairs of purple dots (one on the top line, one on the bottom line).
- Row 3: A solid number 4, followed by two dashed number 4s, and then three pairs of purple dots (one on the top line, one on the bottom line).
- Row 4: A dashed number 4, followed by three single purple dots on the top line.
- Row 5: A blank set of handwriting lines.
- Row 6: A blank set of handwriting lines.
- Row 7: A blank set of handwriting lines.
- Row 8: A blank set of handwriting lines.

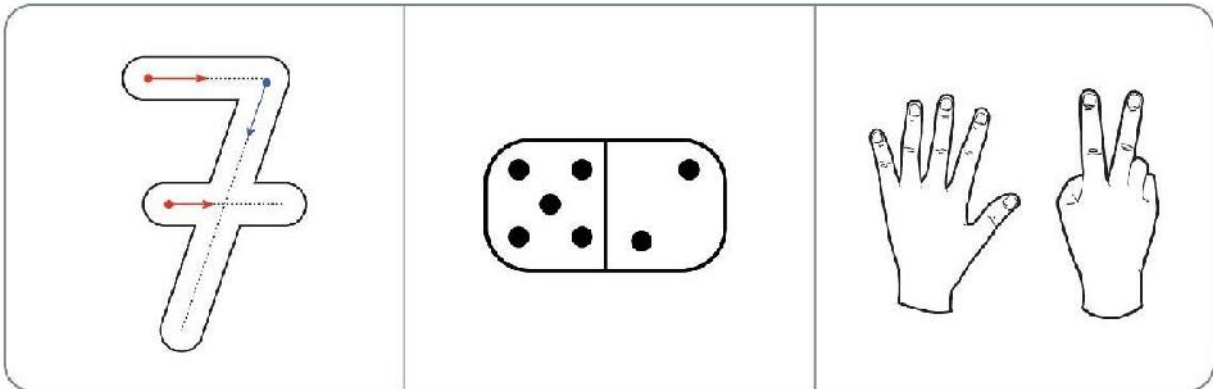

1. Continue les lignes.

Handwriting practice lines for the number 7. The first row shows a horizontal line with a purple dot and a short purple line segment, followed by a series of purple dots. The second row shows a solid blue 7, followed by two dotted 7s, and then a series of purple dots. The third row shows a solid blue 7, followed by two dotted 7s, and then a series of purple dots. The fourth row shows a dotted 7, followed by a series of purple dots. Below these are several empty horizontal lines for independent practice.

ÉCRIRE SON PRÉNOM EN CAPITALES  
D'IMPRIMERIE

---

---

---

---

---

---

## SEMAINE 2

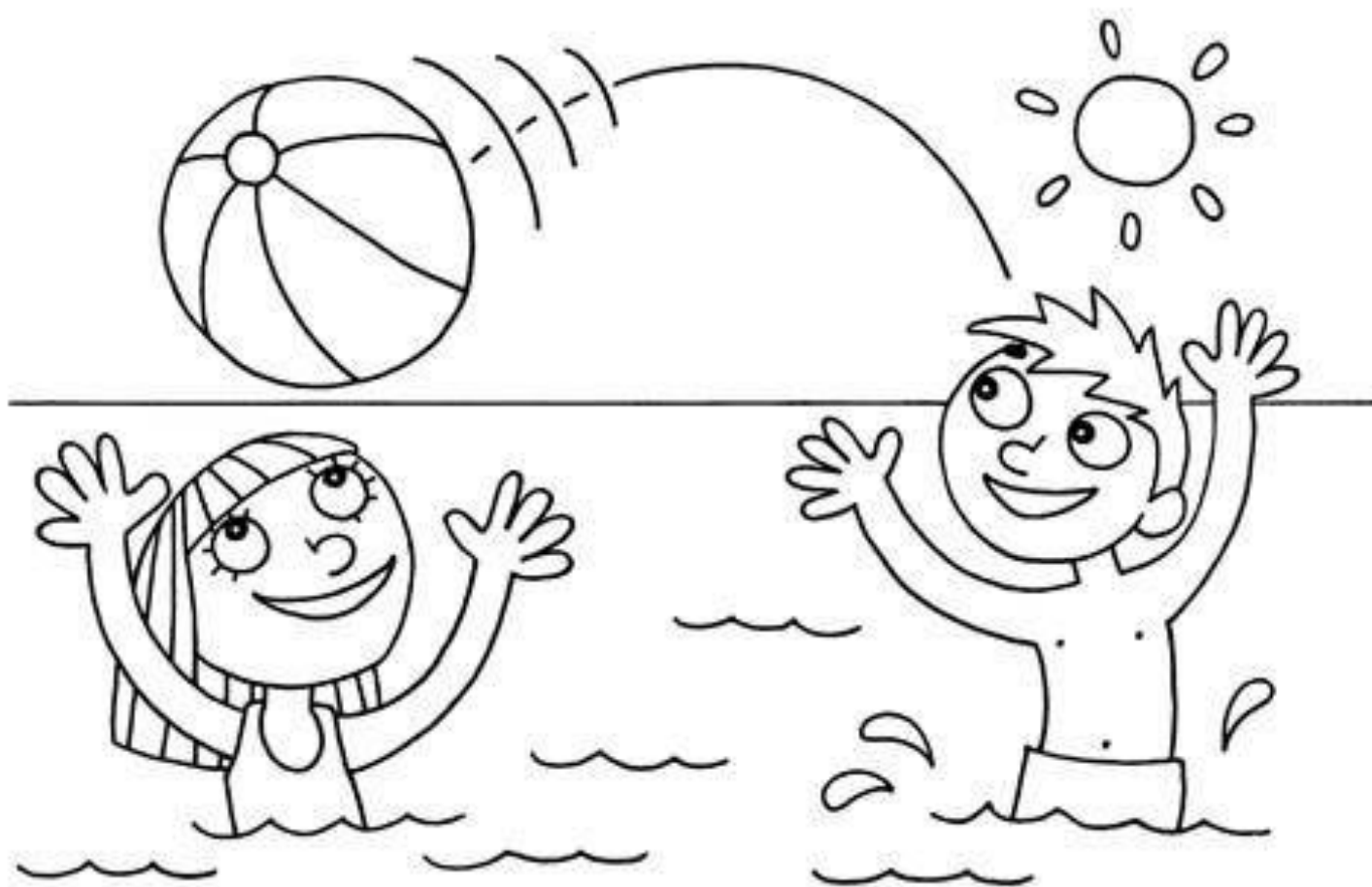



# Les Ponts



# ÉCRIRE LES JOURS DE LA SEMAINE

LUNDI - LUNDI

MARDI - MARDI

MERCREDI - MERCREDI

JEUDI - JEUDI

VENDREDI - VENDREDI

SAMEDI - SAMEDI

DIMANCHE - DIMANCHE

Dans chacun des cas, colorie le plus grand des objets et entoure le plus petit.

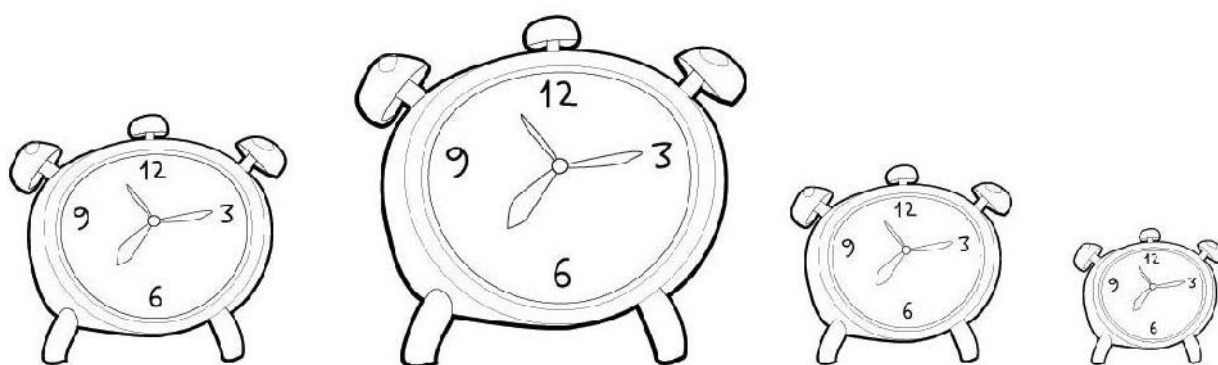
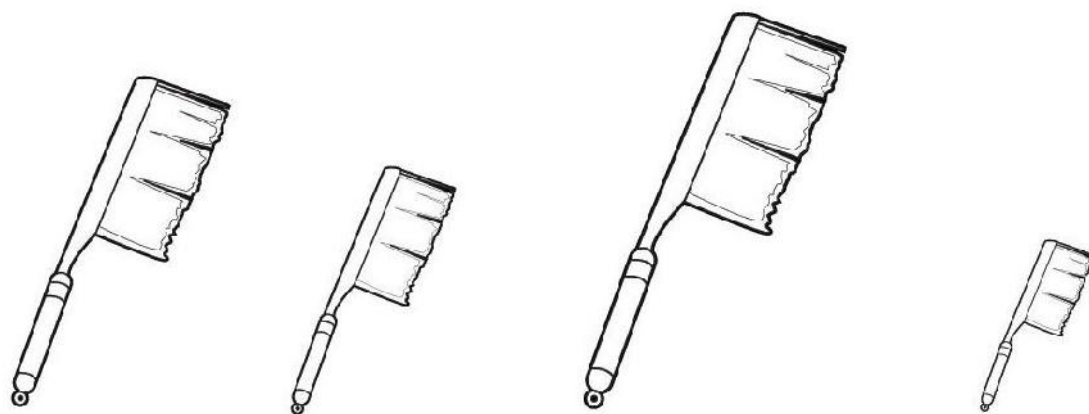
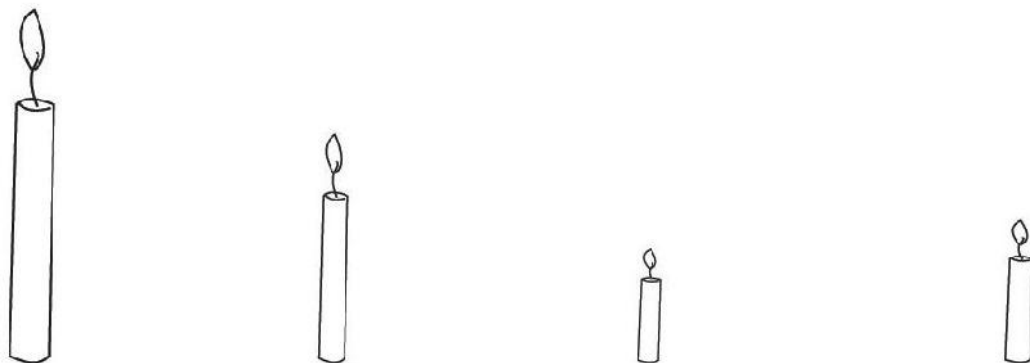

Compte les formes, puis complète le tableau.

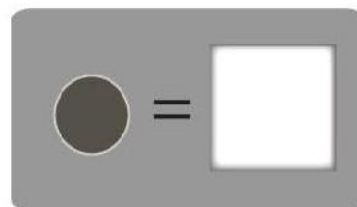
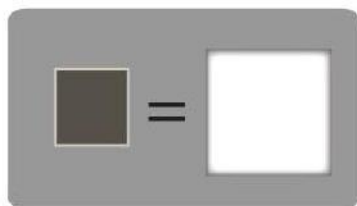
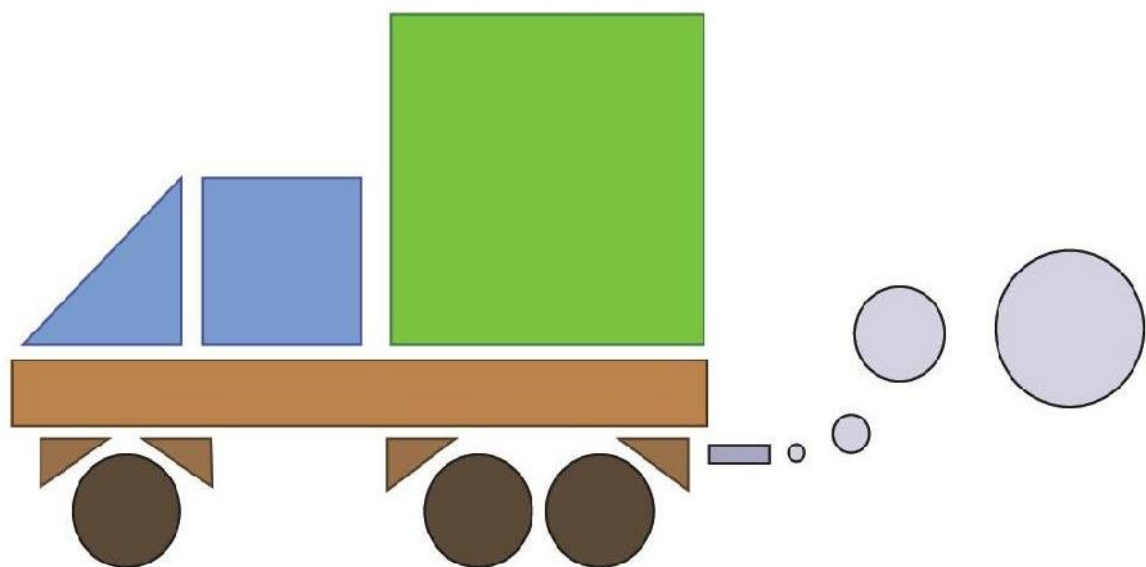

## SEMAINE 3

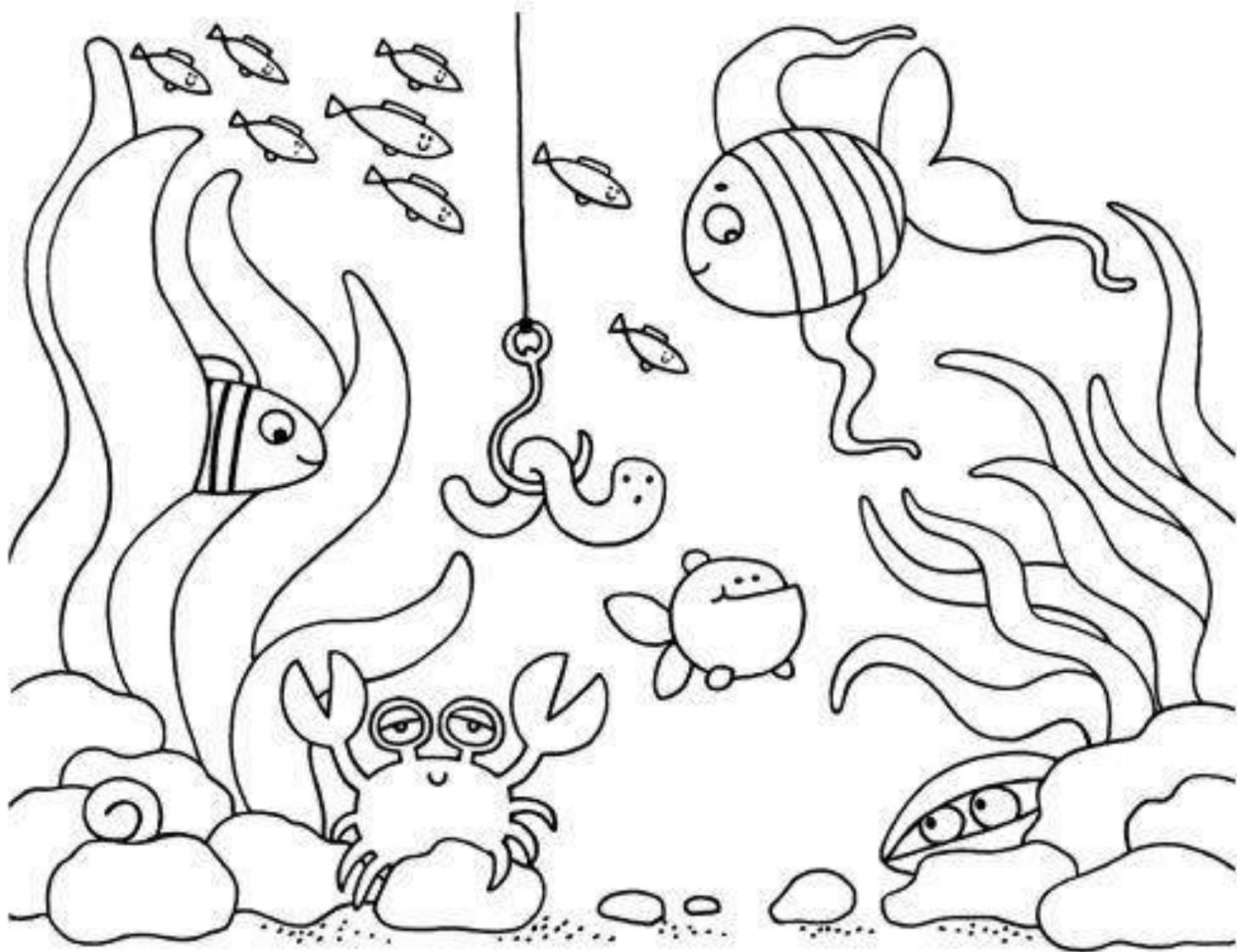

## Les lignes brisées

Retrouve les lettres " L " et entoure-les.

L E F F T L E L  
H R L I L H T H I  
F R E N M L P

Continue les lignes.

Handwriting practice lines for the letter 'L'. The first line shows a solid 'L' with a red arrow indicating the downward stroke, followed by a dashed 'L' for tracing. The second line shows a solid 'L' with red arrows indicating both the downward and rightward strokes, followed by a dashed 'L' for tracing. Below these are two more sets of empty handwriting lines for independent practice.

Retrouve les lettres T et entoure-les.

L E F F T L E L  
H L T I L H T H I  
T F R E N M L P

Continue les lignes.



ÉCRIRE LES MOIS DE L'ANNÉE

**JANVIER**

**FÉVRIER**

**MARS**



ÉCRIRE LES MOIS DE L'ANNÉE

**AVRIL**

**MAI**

**JUIN**

ÉCRIRE LES MOIS DE L'ANNÉE

JUILLET

AOÛT

SEPTEMBRE

ÉCRIRE LES MOIS DE L'ANNÉE

OCTOBRE

NOVEMBRE

DÉCEMBRE

# SEMAINE 4

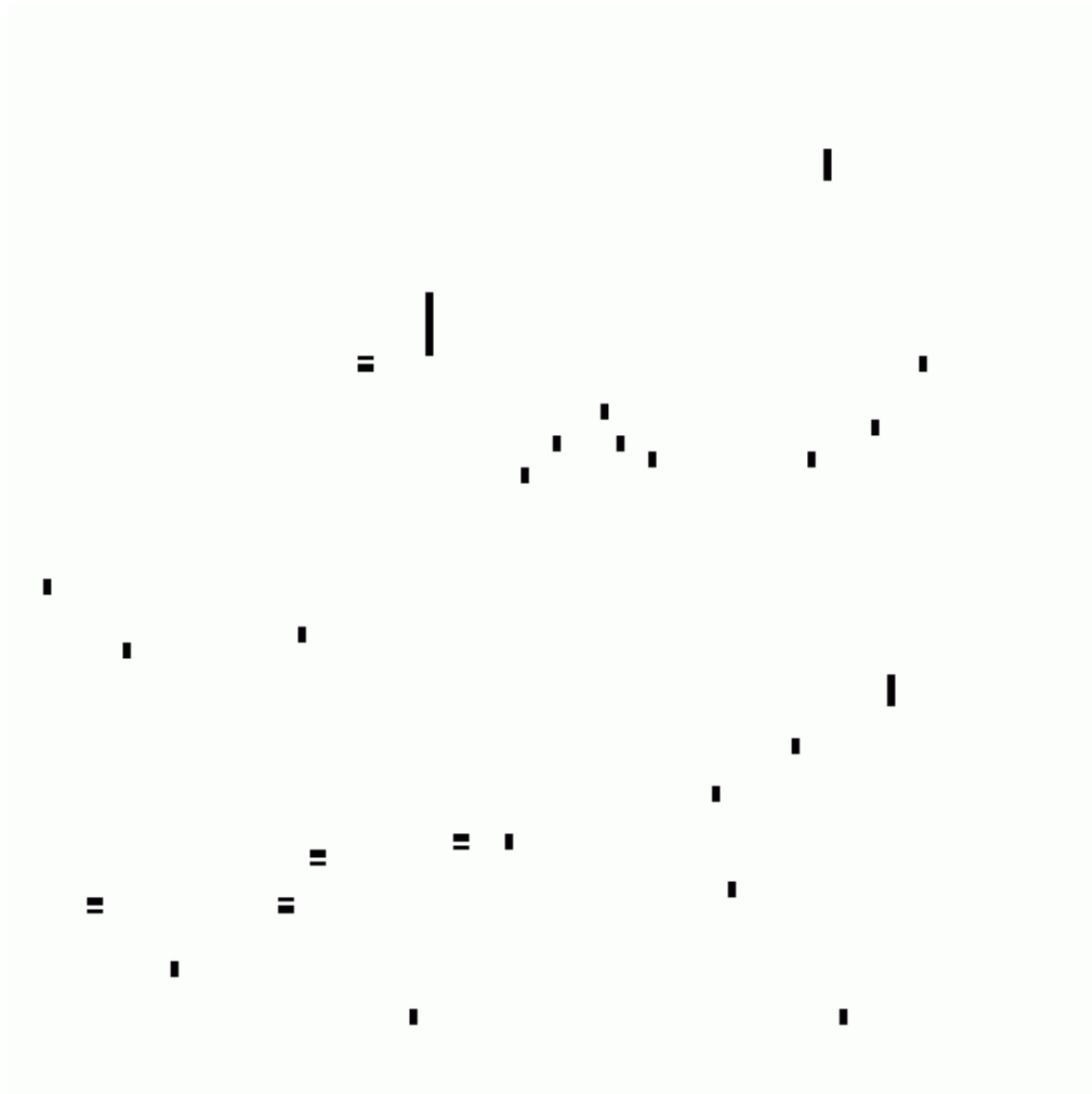

# DESSIN DIRIGÉ

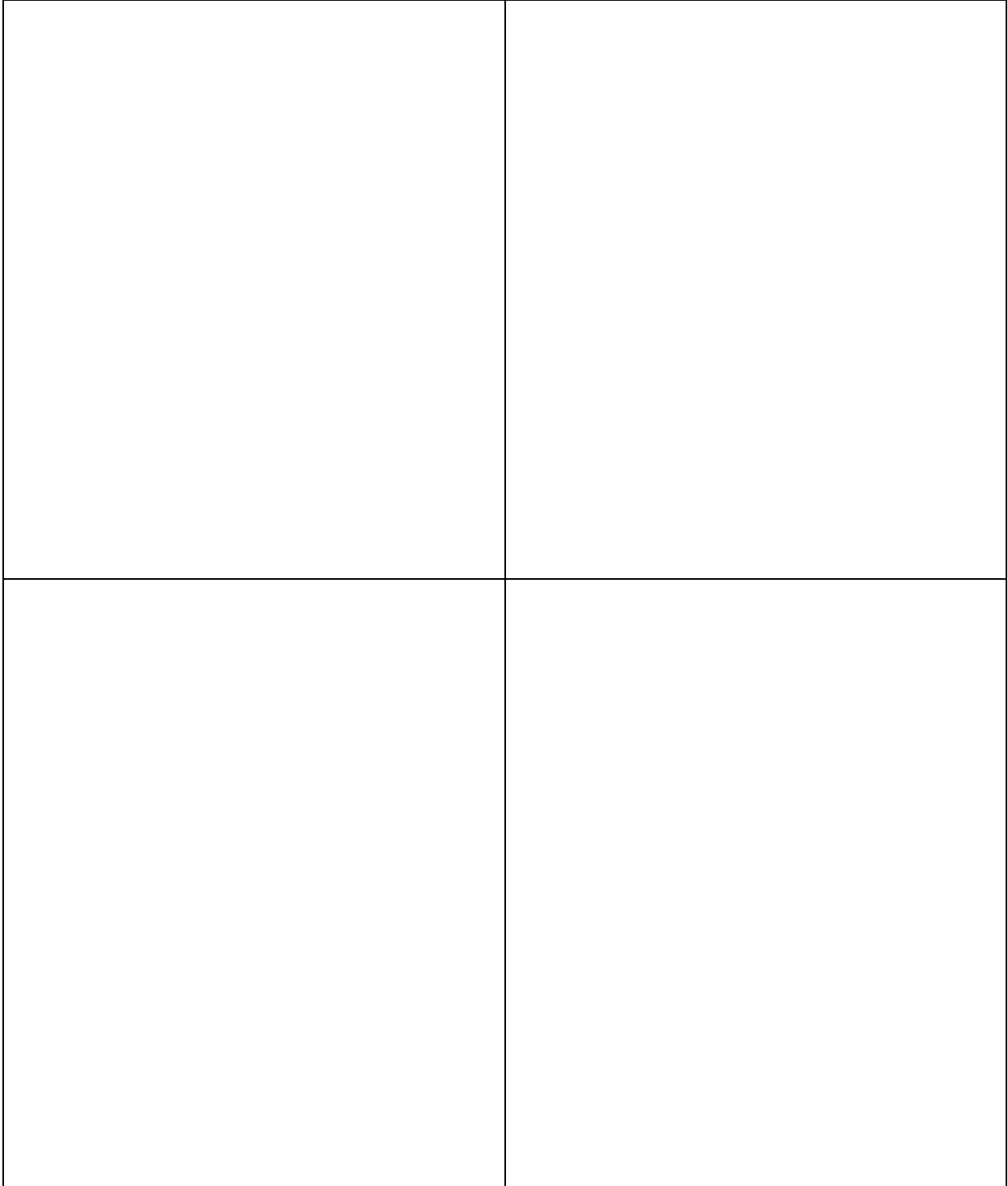













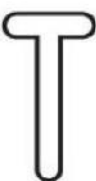

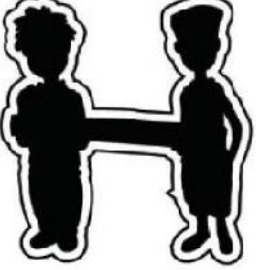

Voir pièce jointe « Dessin dirigé »

## Les boucles



Associer les images.

Trouve à quelle lettre l'ombre se rapproche le plus.

# Dénombrer une collection.

Relie chaque collection au dé qui correspond.



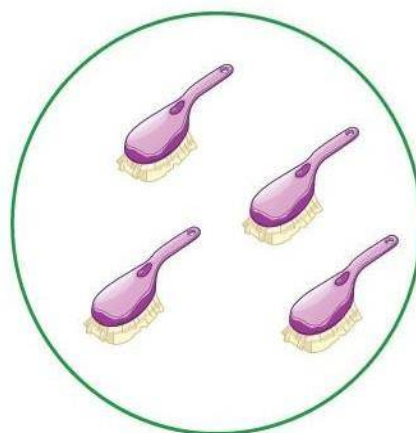
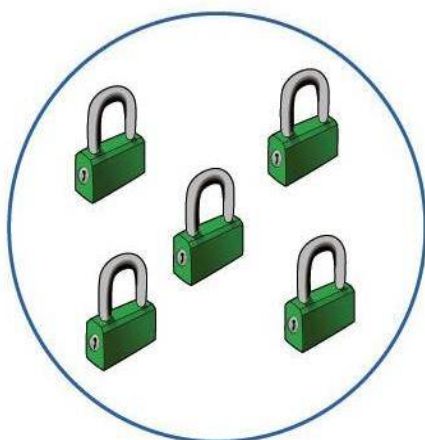
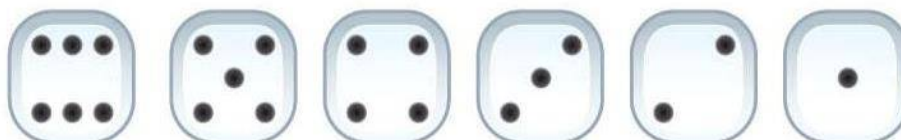
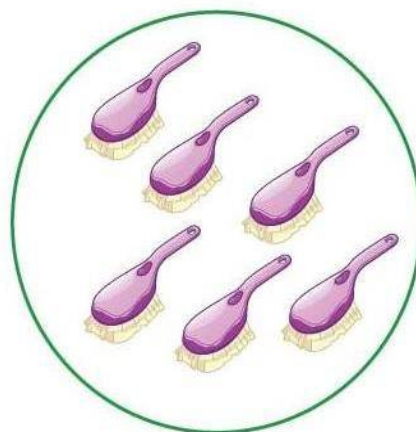
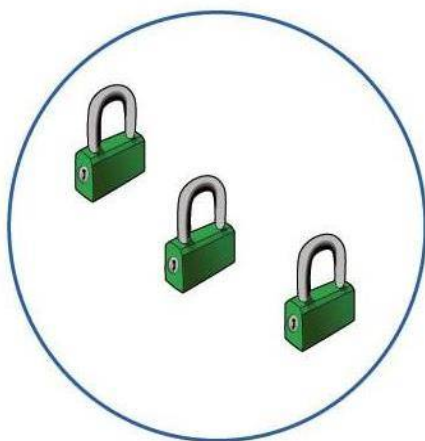

# Dénombrer une collection.

Maintenant, compte les objets dans chaque image et entoure le nombre qui correspond.

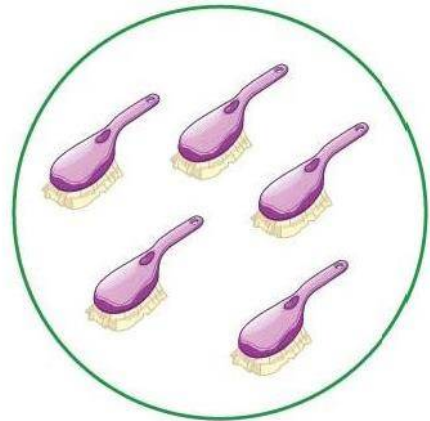
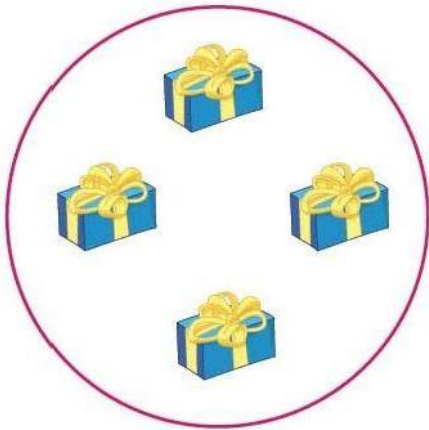

1

2

3

4

5

6

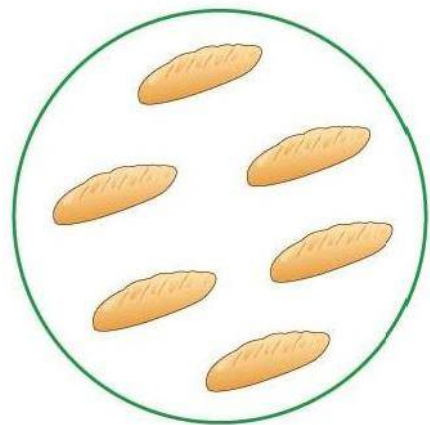
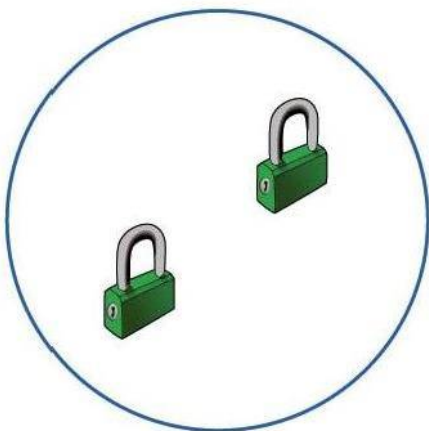

# SEMAINE 5

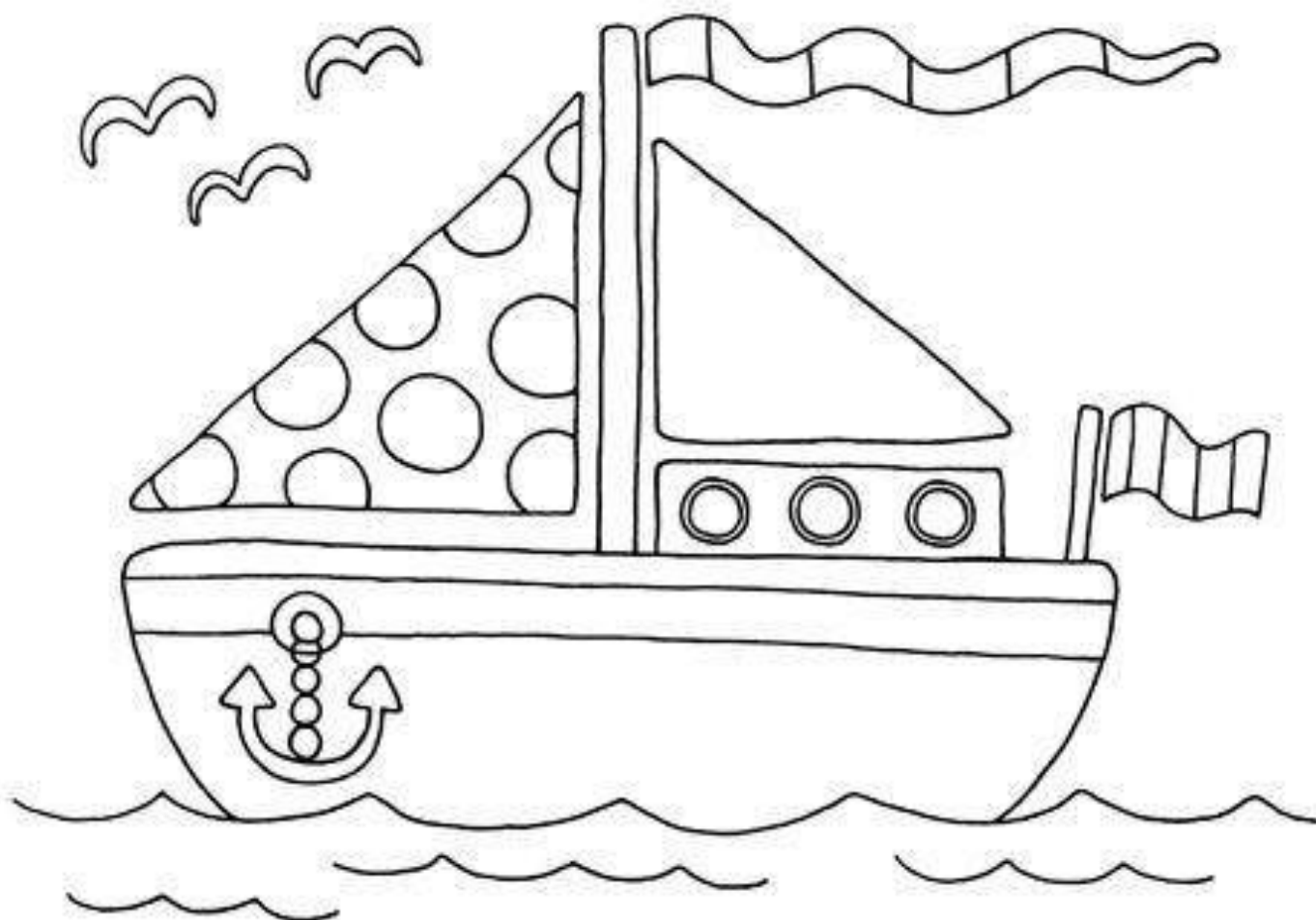

## Les spirales

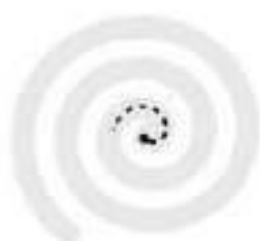
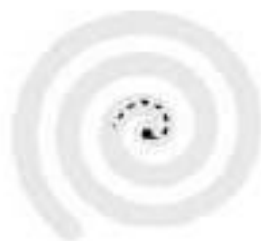



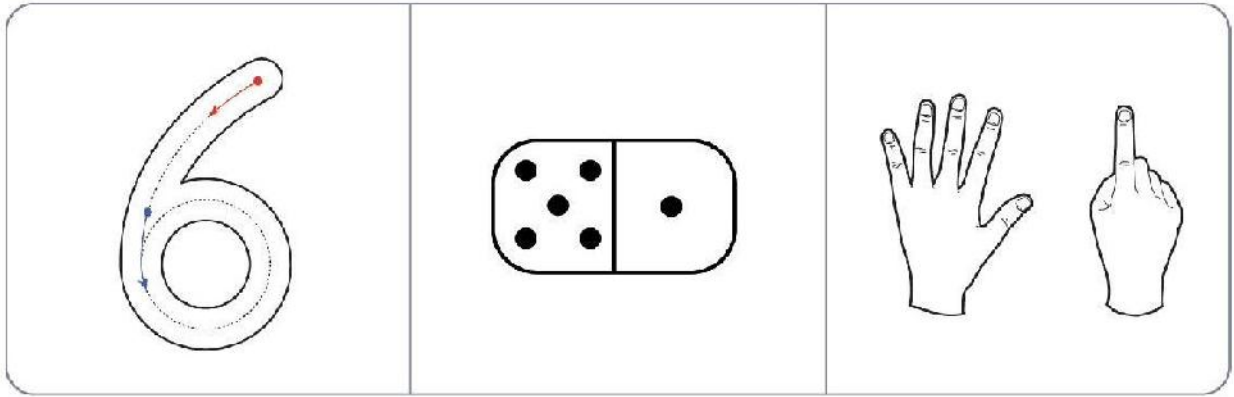

1. Continue les lignes.

Tracing practice lines for the number 6. The first row shows a solid '6' followed by a dashed '6' and then three dots on a line. The second row shows a solid '6', a dashed '6', and then three dots on a line. The third row shows a dashed '6' followed by five dots on a line. Below these are several empty lines for independent practice.

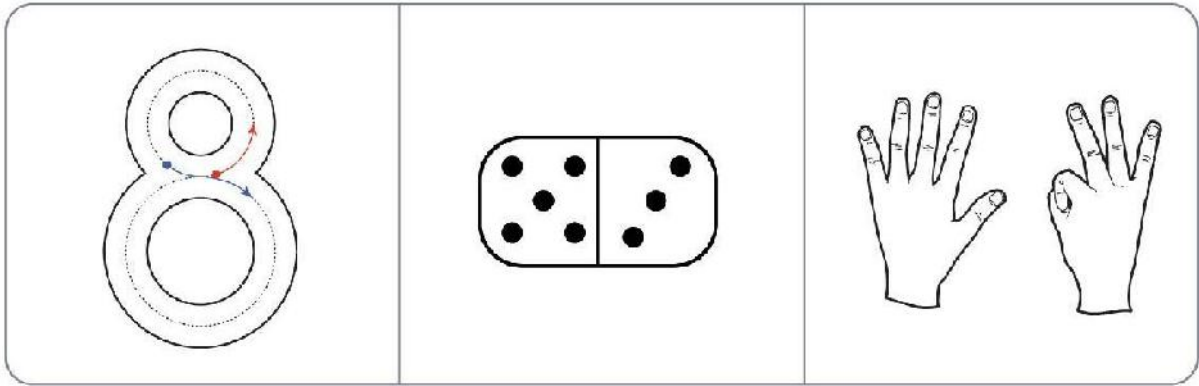

1. Continue les lignes.

Tracing practice lines for the number 8 and hands. Each row contains a solid example, a dotted example, and a dotted example with a starting dot.

Row 1: A solid circle, a dotted circle, a dotted circle with a starting dot, and three starting dots.

Row 2: A solid number 8, a dotted number 8, a dotted number 8 with a starting dot, and three starting dots.

Row 3: A dotted number 8, a starting dot, a starting dot, a starting dot, a starting dot, and a starting dot.

Row 4: A blank line.

Row 5: A blank line.

Row 6: A blank line.

Row 7: A blank line.

Row 8: A blank line.

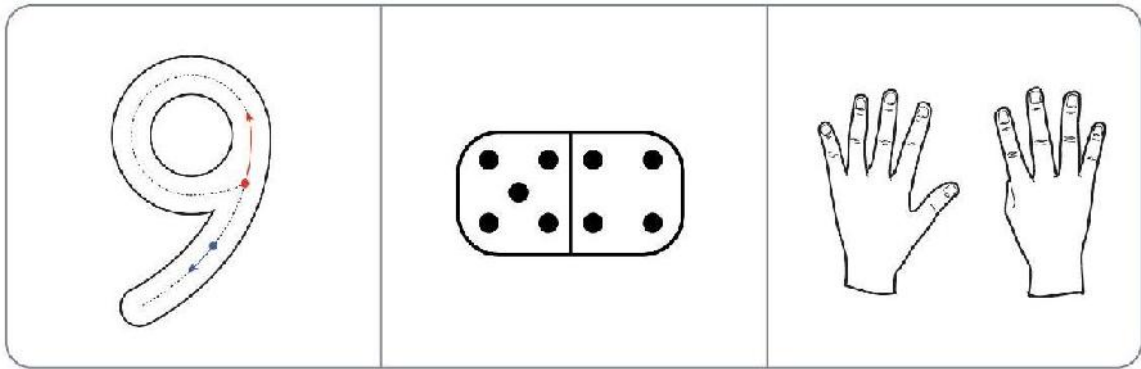

1. Continue les lignes.

Handwriting practice lines for the number 9. Each row consists of two horizontal lines. The first row contains a solid purple circle, two dashed purple circles with arrows, and three purple dots. The second row contains a solid purple '9', two dashed purple '9's with arrows, and three purple dots. The third row contains a solid purple '9' and four purple dots. Below these are four more empty rows for practice.

# SEMAINE 6

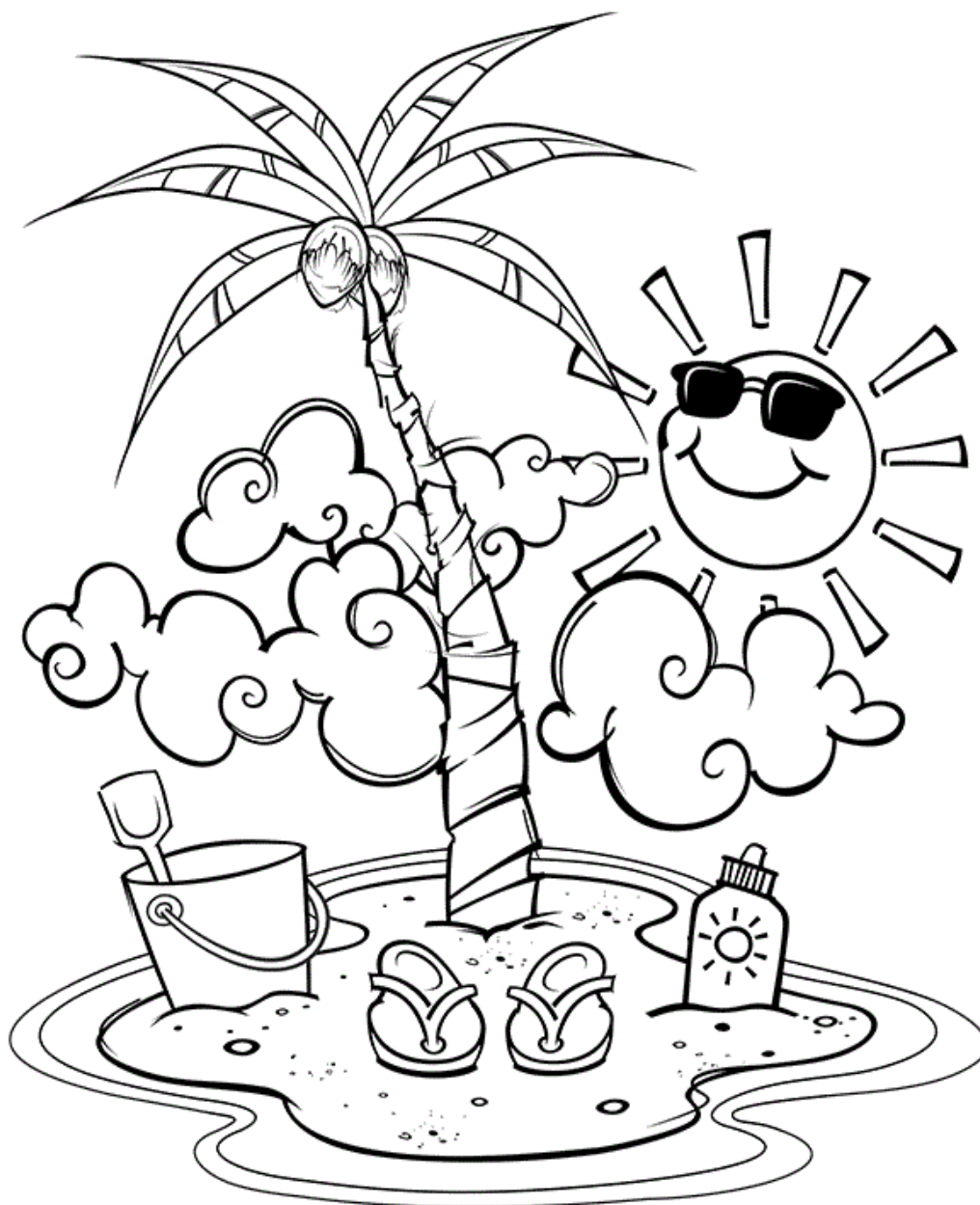



Retrouve les lettres M et entoure-les.

A M F H T M E A L  
V L N A M V F T N M  
N M R V N H L P

Continue les lignes.

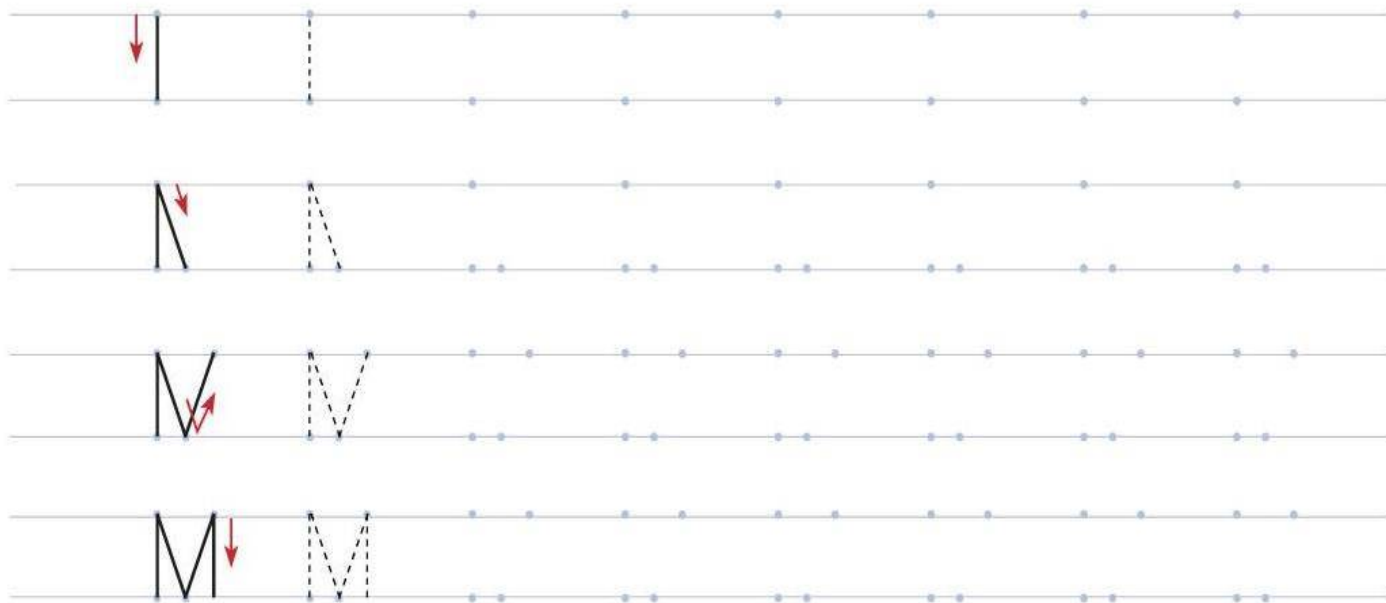

Retrouve les lettres S et entoure-les.

Q C S C V O Q C G  
G O M G L G C S N  
S C Q E S F L O

Continue les lignes.

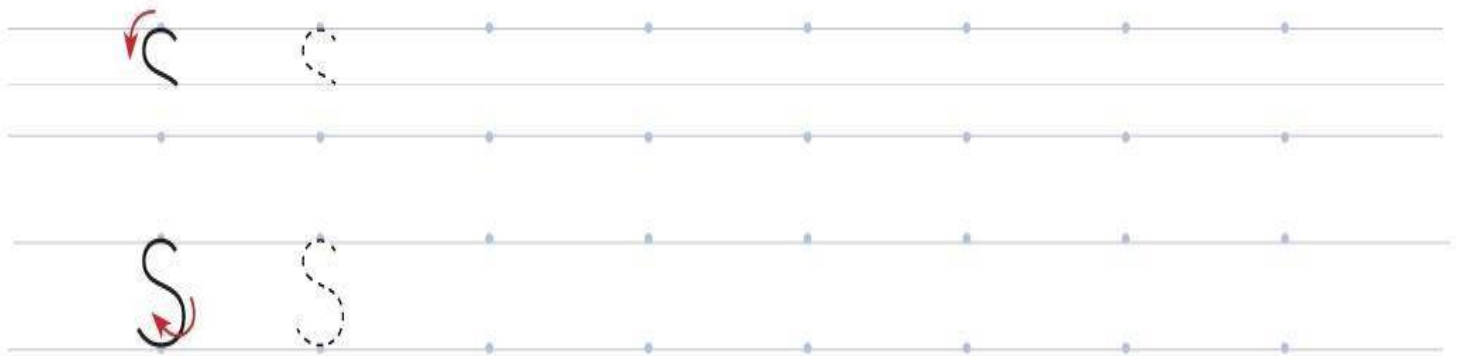

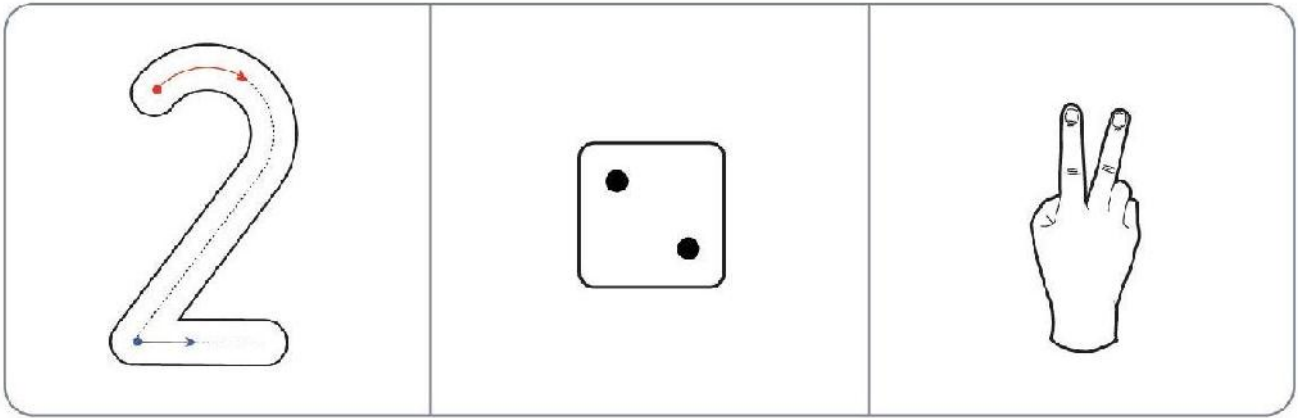

1. Continue les lignes.

Handwriting practice lines for the number 2. Each row consists of a top line, a middle line, and a bottom line. The first row shows a solid blue '2', a dashed '2', and a dotted '2', followed by three purple starting dots on the top line and three orange starting dots on the bottom line. The second row shows a solid blue '2', a dashed '2', and a dotted '2', followed by three purple starting dots on the top line and six orange starting dots on the bottom line. The third row shows a dotted '2', followed by five purple starting dots on the top line and five orange starting dots on the bottom line. The remaining two rows are empty for independent practice.

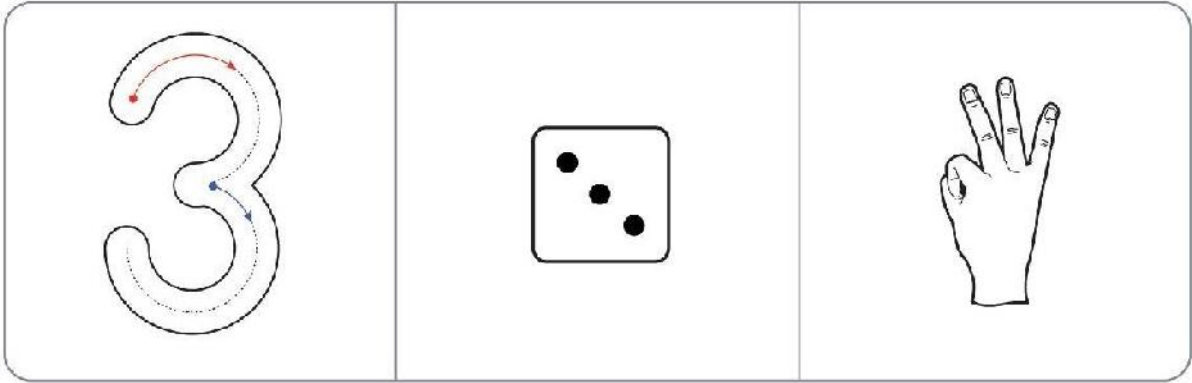

1. Continue les lignes.

Tracing practice for the number 3 on a set of four horizontal lines. The first row shows a sequence of six elements: a solid blue 3, a dashed 3, a dotted 3, a purple dot, a purple dot with a yellow dot below it, and a purple dot with a yellow dot below it. The second row shows a solid blue 3, a dashed 3, a dotted 3, a purple dot with a yellow dot below it, a purple dot with a yellow dot below it, and a purple dot with a yellow dot below it. The third row shows a dotted 3, followed by five purple dots. The remaining two rows are empty for independent practice.

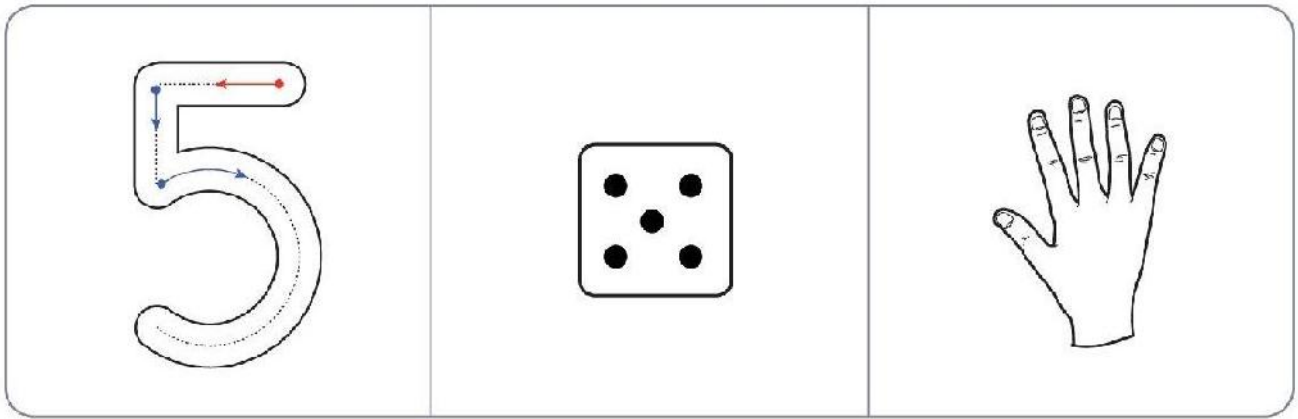

1. Continue les lignes.

Tracing practice on a four-line grid. The first row shows a solid horizontal line with a purple dot at the start, followed by a dotted line with a purple dot at the start, and then four more dotted lines with purple dots at the start. The second row shows a solid L-shaped corner with a purple dot at the top-left, followed by a dotted L-shaped corner with a purple dot at the top-left, and then four more dotted L-shaped corners with purple dots at the top-left. The third row shows a solid number 5 with a yellow dot at the bottom-left, followed by a dotted number 5 with a yellow dot at the bottom-left, and then four more dotted number 5s with yellow dots at the bottom-left. The fourth row shows a dotted number 5 with a purple dot at the top-left, followed by four empty dotted number 5s with purple dots at the top-left. The remaining two rows are empty for independent practice.

# Écrire les nombres de 1 à 6.

1. Pour chaque domino, écris dans la bulle de droite le chiffre qui correspond.

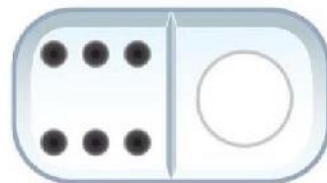
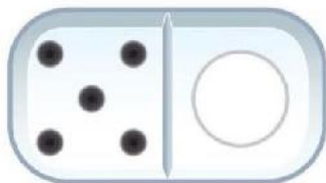
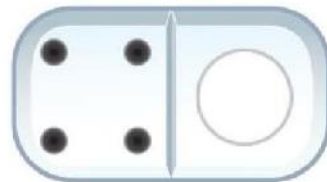
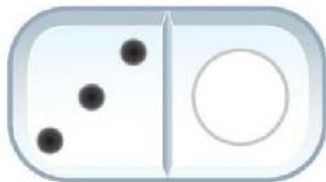
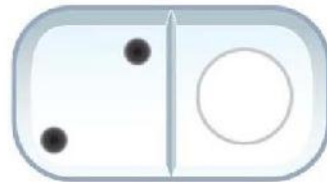
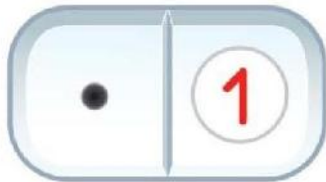

2. Écris les chiffres.

1	1	1
2	2	2
3	3	3

فرض العطلة الصيفيّة الروضة الثانية

MS 2019-2020

الدخول إلى الموقع الإلكتروني

حروفي مع بركة

<http://w.chippewavillageresort.com/alphabitics>

تعلم وألعب

أوراق العمل

## Activités ludiques pour aller plus loin-MS / 2019-2020

### Histoires à écouter :

- Le loup qui avait la tête dans les étoiles <https://www.visiolivres.com/index.php/2020/04/14/le-loup-qui-avait-la-tete-dansles-etoiles/>
- La grenouille qui avait une grande bouche <https://www.visiolivres.com/index.php/2020/04/01/la-grenouille-qui-avait-unegrande-bouche/>
- Robin est confiné à la maison <https://youtu.be/jISFFzYeLQ4>

### Phonologie :

- Le son [a] <https://www.logicieleducatif.fr/francais/lecture/lecture-son-a.php>
- Le son [i] <https://www.logicieleducatif.fr/francais/lecture/lecture-son-i.php>
- Le son [o] <https://www.logicieleducatif.fr/francais/lecture/lecture-son-o.php>
- Le son [u] <https://www.logicieleducatif.fr/francais/lecture/lecture-son-u.php>
- Le son [t] <https://www.logicieleducatif.fr/francais/lecture/lecture-son-t.php>
- Le son [l] <https://www.logicieleducatif.fr/francais/lecture/lecture-son-l.php>
- Le son [m] <https://www.logicieleducatif.fr/francais/lecture/lecture-son-m.php>
- Le domino des syllabes finales <https://learningapps.org/view12111664>
- L'alphabet <https://www.logicieleducatif.fr/francais/vocabulaire/alphabet.php>

### Pré-Mathématiques :

- Défi algorithme : <https://www.youtube.com/watch?v=crzQ3LG0-H4>
- Associer le chiffre à sa constellation : <https://learningapps.org/3324527>
- Associer le chiffre à sa constellation : <https://learningapps.org/watch?v=pp1aauCYa19>
- Associer le chiffre à sa constellation : <https://learningapps.org/watch?v=p22hi5d4j19>



# Chenille

.....

1. Dessine d'abord la tête et le corps.
2. Gomme la ligne superflue et fais ensuite les yeux et la bouche.
3. Termine les yeux et donne des pattes à ta chenille.
4. Termine le corps par des poils et des rayures.

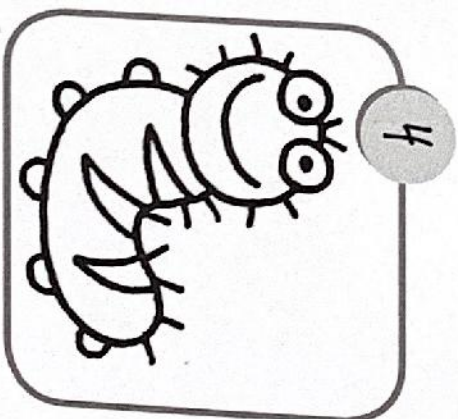
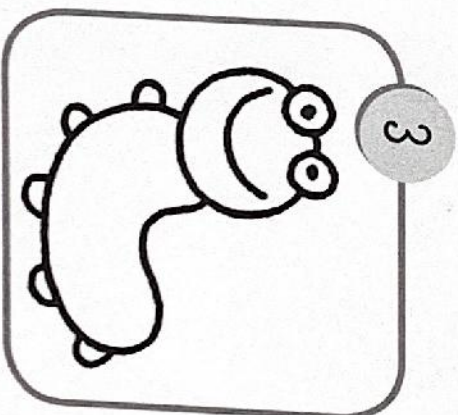
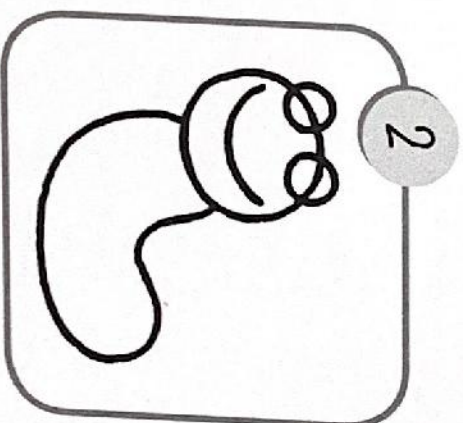
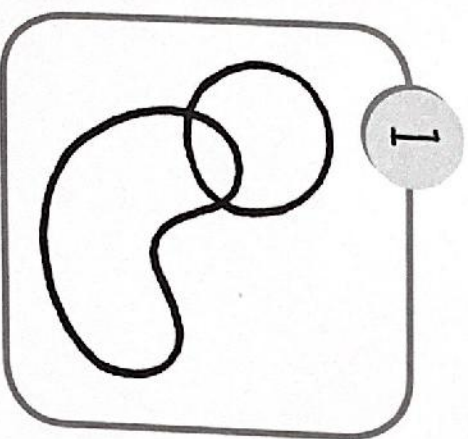
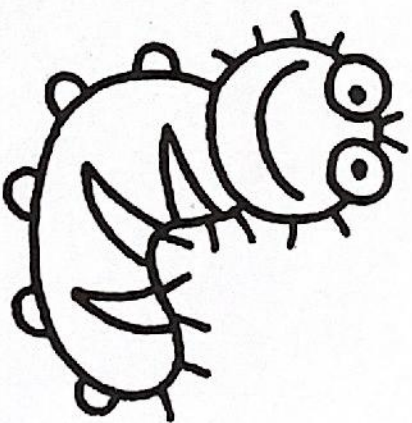

# Abeille .....

1. Commence par deux cercles.
2. Gomme la ligne superflue et fais les deux ailes.
3. Dessine les pattes et le dard.
4. N'oublie pas les antennes, les yeux, le nez, la bouche et les rayures sur le corps.

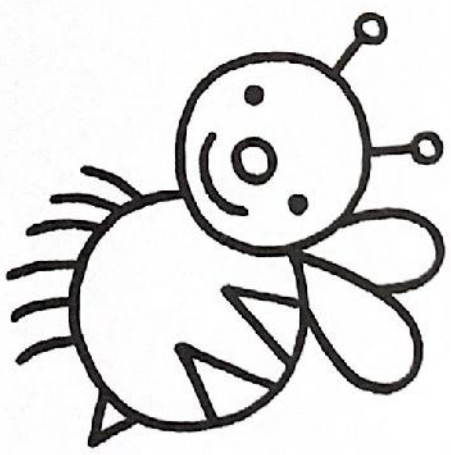

1

2

3

4

# Escargot .....

1. Commence par deux cercles, un petit et un grand.
2. Dessine ensuite le corps mou.
3. Fais ensuite deux antennes.
4. Pour finir, n'oublie pas la spirale de la coquille, la bouche et les yeux.

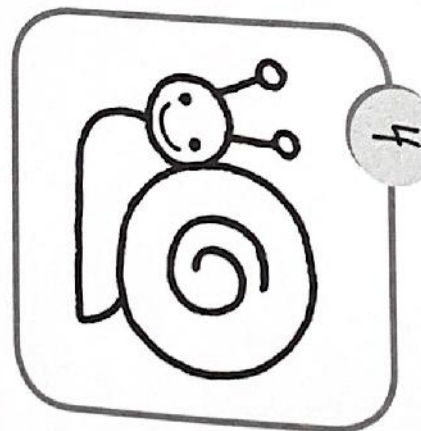
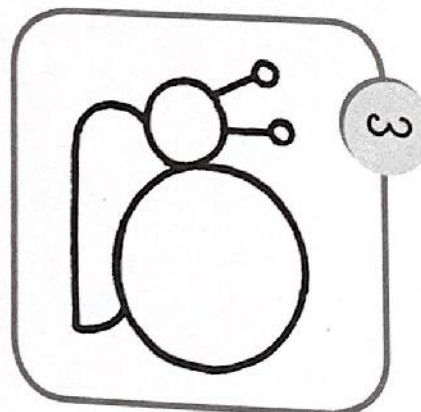
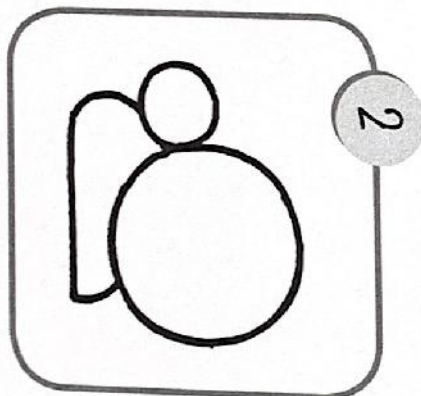
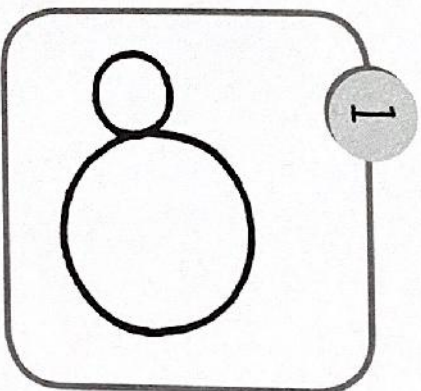

# Paon .....

1. Trace un grand cercle et un plus petit dedans.
2. Fais le corps et les deux pattes.
3. Dessine les plumes de la queue, l'œil de profil, le bec et les ailes.
4. Gomme les lignes superflues et décore les plumes.

